

H. K. Smith,
Friction-Clutch Pulley.

N^o 89,024.

Patented July 14, 1868.

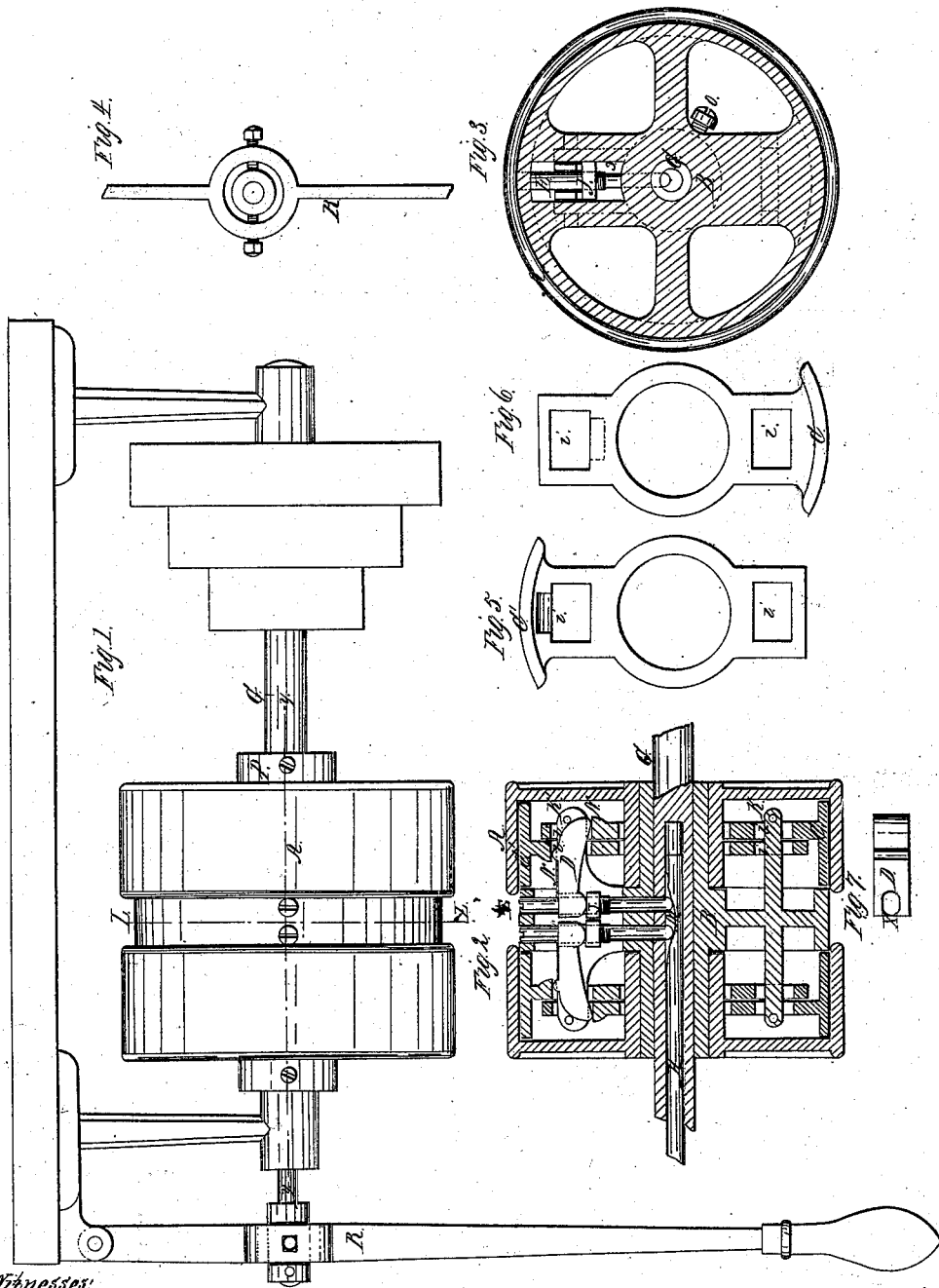

Witnesses:
Geo. S. Clark
George Chynoweth

Inventor:
H. K. Smith

United States Patent Office.

H. K. SMITH, OF NORWICH, CONNECTICUT.

Letters Patent No. 80,024, dated July 14, 1868.

IMPROVEMENT IN FRICTION-CLUTCH PULLEY.

The Schedule referred to in these Letters Patent and making part of the same.

TO ALL WHOM IT MAY CONCERN:

Be it known that I, H. K. SMITH, of Norwich, county of New London, and State of Connecticut, have invented a new and useful Improvement in Friction-Clutch Pulleys; and I do hereby declare that the following is a full, clear, and exact description thereof, which will enable others skilled in the art to make and use the same, reference being had to the accompanying drawing, forming part of this specification, in which it is shown that the following desirable points are obtained:

First, that the hub or bearing of the pulley, while running loose, shall be in a direct vertical line with the face of the pulley, thereby producing an equal amount of wear at each end of the hub or bearing of the pulley.

Second, that when using two pulleys, as for reversing motion, the pulleys may be brought near together, and also made perfectly smooth externally, and free from any liability to wind up the belt when thrown off.

Third, in being self-adjusting, always producing an equal amount of pressure on either side of the pulley.

Figure 1, in the drawing, is an external perspective view of a pair of pulleys, attached to a shaft, with cone-pulley, hangers, and shipper, as used for the counter-shaft of an engine-lathe or other machine, where it is desirable to reverse the motion of the shaft.

Figure 2 is a longitudinal section, taken in the plane of the line *y y*.

Figure 3 is a transverse vertical section, taken in the plane of the line *L L*.

Figure 4 is an end view of the shipper-attachment, showing the universal joint.

Figures 5 and 6 are plans of the friction-pieces *C C'*, seen in fig. 2.

Figure 7 is a plan or top view of the lever *D*, shown in fig. 2.

Similar letters of reference indicate corresponding parts.

Although the drawing represents two pulleys, it will only be necessary to describe the parts and operation of one, as it is plain that the invention is as applicable to a single as a double pulley.

G, in the drawing, represents the shaft, which is bored hollow at one end, in the direction of its length; a sufficient distance to pass the place occupied by the pulley.

B is a spider, with a long hub, through which the hollow shaft *G* is fitted, and secured by the set-screw *O*, or its equivalent.

D is a lever, acting against the pieces *C C'*, to move them in opposite directions.

C C' are friction-pieces, which are fitted loosely over the protruding lateral arms *K K'* of the spider *B*, having openings for the purpose, *i' i'*, through which, also, the lever *D* passes, having bearing-points on it, as shown at *N N*, against the sides of the opening *i' i'*, each serving as a fulcrum on which the lever *D* acts to move the other.

E is a steel pin, passing in a vertical line through the rim of the spider *B*, and the opening or slot in the end of the lever *D*, as seen at *x* in fig. 7, and having a screw-thread in the nut *J*, (on which the end of the lever *D* rests,) then passing down through the hub of the spider *B* and into the hollow shaft *G*, and there resting on the bottom of an inclined groove or indenture made in the side of the steel sliding bar or rod *H*, the bottom of said groove or way being of peculiar form, as seen at *M*.

A is the outer shell or pulley proper, whose hub is fitted over and has its bearing on the hub of the spider *B*, (when running loose,) and the rim is turned out to pass freely over the segmental ends of the friction-pieces *C C'*.

P is a collar set to the shaft, to prevent the pulley *A* from sliding off the hub of the spider *B*, when running loose.

R is the shipper-lever, hung by a joint, in the usual manner, above the shaft, and attached to the sliding bar or rod *H*, in the hollow shaft *G*, by means of a universal joint, seen in figs. 1 and 4.

Now, it is plain to be seen that, by moving the shipper-lever *R* in the proper direction, the sliding bar *H* will, by means of its inclined groove or way, *M*, in connection with the pin *E* and nut *J*, raise the end of the lever *D*, which will, by its peculiar arrangement in the openings *i' i'* in the friction-pieces *C C'*, operate in such a manner as to force their segmental ends out in opposite directions, and thus cause them to impinge tightly

against the inner periphery of the pulley-rim A, thus, by means of the spider B and set-screw O, making the connection, and causing the shaft G to revolve with the pulley A.

Also, that, by a reverse motion of the shipper-lever R, the action of the parts will be reversed, thus allowing the pulley A to revolve freely on the hub of the spider B, while the shaft G remains at rest.

Also, in the case of a double pulley, as represented in the drawings, the shaft can be put under control of the other pulley, and made to rotate in an opposite direction.

Also, if by wearing of the end of the pin E, or the bottom of the groove M, or by any other means, the pressure of the friction-pieces C C' against the pulley A is not sufficient to drive the work required, the pin E, by means of its slot in the outer end, may be turned in such a way as to raise the nut J, on which the end of the lever D rests, whereby it will be seen that any amount of pressure may be obtained by the friction-pieces C C' against the rim of the pulley A, the nut J being prevented from turning with the pin by the two sides of the opening s in the arm of the spider B, in which the nut is placed, and, by the peculiar operation of the lever D in the opening s' s', the two friction-pieces C C' are each forced with equal pressure against the rim of the pulley A, therefore requiring no nice adjustment to cause an equal pressure on each side.

I claim as new, and desire to secure by Letters Patent—

1. The pin E and nut J, in connection with the levers D.
2. The friction-pulley, constructed and arranged substantially as described and for the purpose specified.

H. K. SMITH.

Witnesses:

GEO. L. CLARK,
GEORGE SYMONDS.